



The Konftel 300M User Guide

ENGLISH

OmniSound® HD – Optimal sound

By incorporating full duplex audio, the patented audio technology OmniSound® guarantees the audio conference an impressive and crystal clear sound in both directions through a hypersensitive microphone with 360° sound pickup and speakers that provide powerful sound distribution to all participants.

OmniSound® HD offers HD audio transmission for VoIP calls. In addition features like echo cancellation, background noise suppression which minimizes distracting background noise and an equalizer for personal adjustment of the sound's various characteristics are also included. Move freely around the room, talk, discuss and debate while retaining great sound quality that is entirely free from irritating sound clipping, damping or echoes. It's as close as you can get to natural sound.

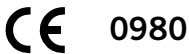

Konftel AB hereby declares that this conference unit complies with all essential requirements and other relevant provisions of Directive 1999/5/EC.

See www.konftel.com/doc for a complete declaration.



Warning!

Do not expose the Konftel 300M, charging stand or batteries to water or moisture.



Warning!

Do not open the casing of the Konftel 300M.



Warning!

Only use the power adapter provided to connect the unit to the mains.



Warning!

Only use the battery provided or a Konftel-recommended replacement battery.



Warning!

Do not attempt to open or modify the battery.



Warning!

Extreme heat, short-circuiting or any attempt to modify the battery may cause it to ignite or explode.

TABLE OF CONTENTS

Description	2	Recording	19
General.....	2	Starting a recording	19
Maintenance	2	Mute function.....	19
Keypad	4	Hold	19
Display screen.....	5	Ending a recording.....	19
Navigation and selection in menus	6	Listening to a recording.....	20
General	7	Managing recordings.....	21
Unpacking	7	Adjusting the recording indicator	21
Connecting and installing the unit	8	Displaying recording feature status.....	21
Connection to a PC.....	9	Messages	22
Bridge connection.....	9	Read and erase a message	22
Recharging batteries	10	Send a message	22
Answering and making calls	11	Settings	23
Answering calls.....	11	Appearance	23
Making calls.....	11	Adjusting date and time	23
Making multi-party calls	11	Sound	24
During a call	12	Security.....	24
Adjusting the speaker volume.....	12	Enable SIM card	25
Placing calls on temporary hold.....	12	Network.....	25
Ending calls	12	Sleep mode.....	26
Conference guide	13	Software	26
Making multi-party calls	13	Checking status.....	26
Answering incoming calls during a call	13	Set call forwarding.....	26
Managing multi-party calls	13	Upgrading software	27
Creating conference groups.....	14	Upgrading from a PC.....	27
Making conference group calls	14	Technical specifications	28
Displaying conference group participants	15	Service and guarantee	30
Editing conference groups	15		
Deleting conference groups.....	15		
Delete all conference groups.....	15		
Displaying conference guide status.....	16		
Phonebook	17		
Searching for contacts	17		
Adding contacts	17		
Editing contacts	17		
Deleting contacts.....	18		
Deleting all contacts	18		
Copying contacts	18		
Displaying phonebook status.....	18		

DESCRIPTION

GENERAL

The **Konftel 300M** is a battery-operated wireless conference phone that can be connected to mobile networks (GSM/3G) or PCs (USB).

The conference phone has a host of innovative features:

- A mobile unit that provides about 30 hours of talk time without having to recharge.
- OmniSound® HD audio technology.
- USB connectivity allows the phone to be used to make VoIP calls.
- Conference guide for easy set-up of multiparty calls.
- Potential to bridge calls between USB and the mobile network.
- Record your meetings with an SD memory card so that you can listen to them later on.
- Can be upgraded with smart features, making it future-proof.
- Two-year guarantee.

MAINTENANCE

Clean the equipment with a soft, dry cloth. Never use liquids.

DESCRIPTION

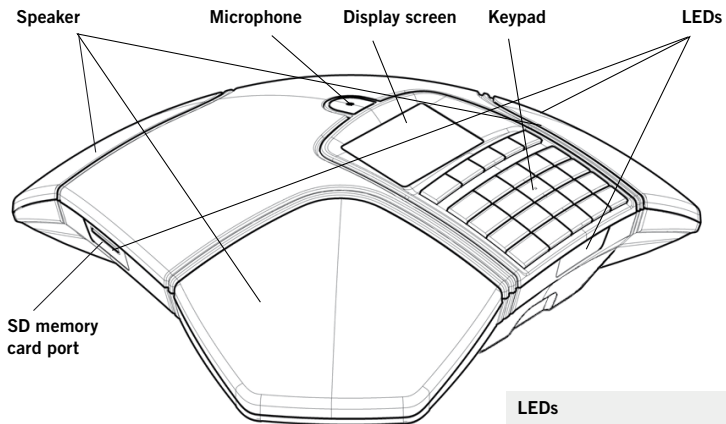

LEDs

Flashing blue	Incoming call
Steady blue light	Call in progress
Flashing red	Hold, microphone and speaker turned off
Steady red light	Mute, microphone turned off

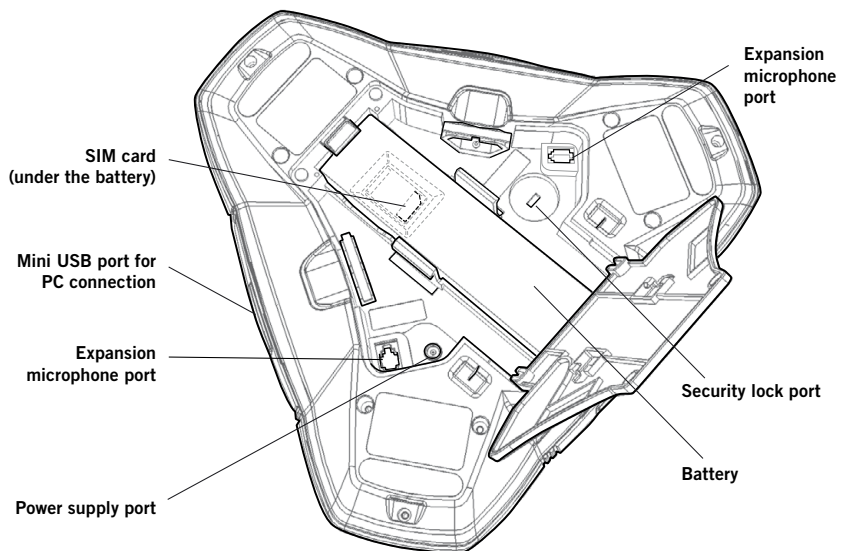

KEYPAD

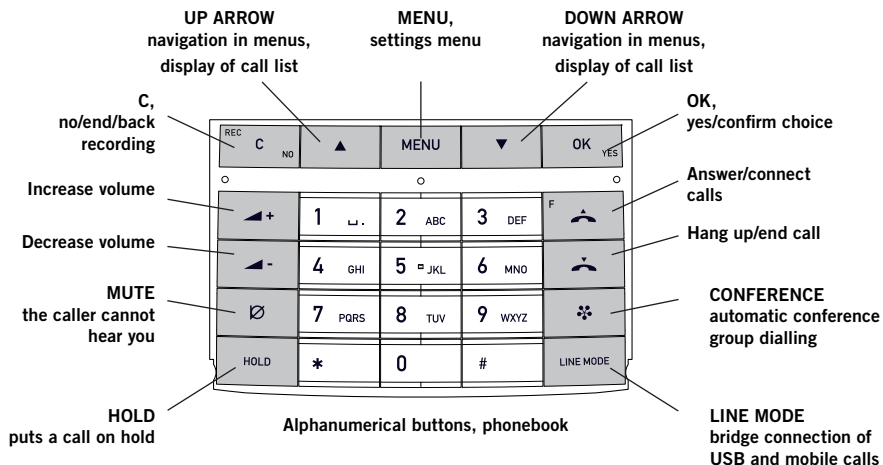

Writing text

Each button contains letters and characters – more than those shown on the button (see illustration below). Press the same button repeatedly to change to another character. If there are two letters under the same button that you want to enter one after the other, you need to pause slightly before entering the second letter.

Press the **C** button to delete the last character you entered.

1 [space] . - 1

2 ABC A B C Å Ä Å À 2

3 DE D E F É È 3

4 GHI G H I 4

5 JKL J K L 5

6 MN M N O Ö Ø Ñ 6

7 PQRS P Q R S 7

8 TUV Ü Ú 8

9 WXYZ W X Y Z 9

*

0 0

#

DESCRIPTION

DISPLAY SCREEN

On Hook

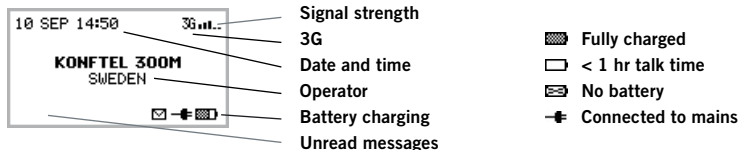

Off Hook

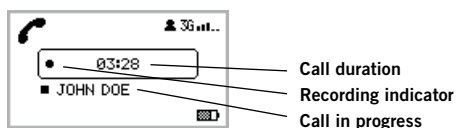

Calls between several parties

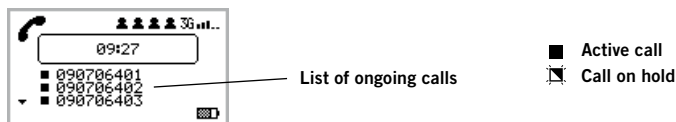

Menu

Press **MENU** to switch to and from a menu.

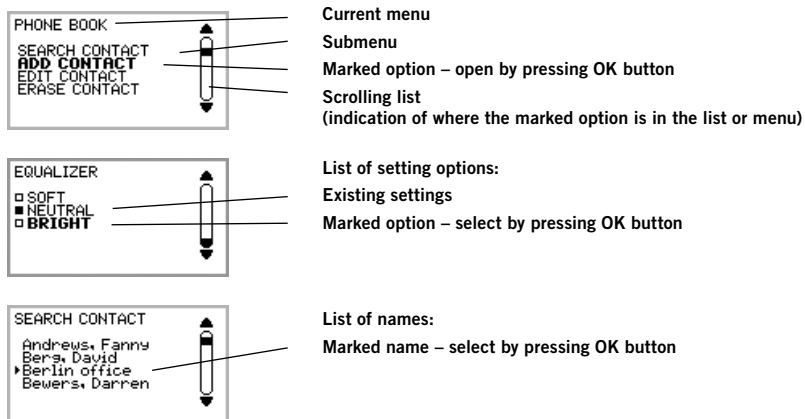

NAVIGATION AND SELECTION IN MENUS

- ⇒ Press **MENU**.
- ⇒ Select the option you want from the menu using the arrow buttons.
- ⇒ Confirm by pressing **OK** to select the marked option.
- ⇒ Cancel the setting or go back one level in the menu by pressing **C**.
- ⇒ Quit the menu by pressing **MENU** again.
- ⓘ Note that after you have made changes to a setting, you must press **OK** to activate the setting.
- 🌐 It is possible to open a menu option directly by pressing the number button that corresponds to the position of the option in the menu (e.g. 2 to open PHONE BOOK and then 3 to select EDIT CONTACT).

Writing style in instructions

In the instructions, **MENU > SETTINGS** means you should:

- ⇒ Press **MENU**.
- ⇒ Mark the **SETTINGS** option using the arrow buttons and confirm by pressing **OK** to open the menu (or press button number **6**).

Menu tree

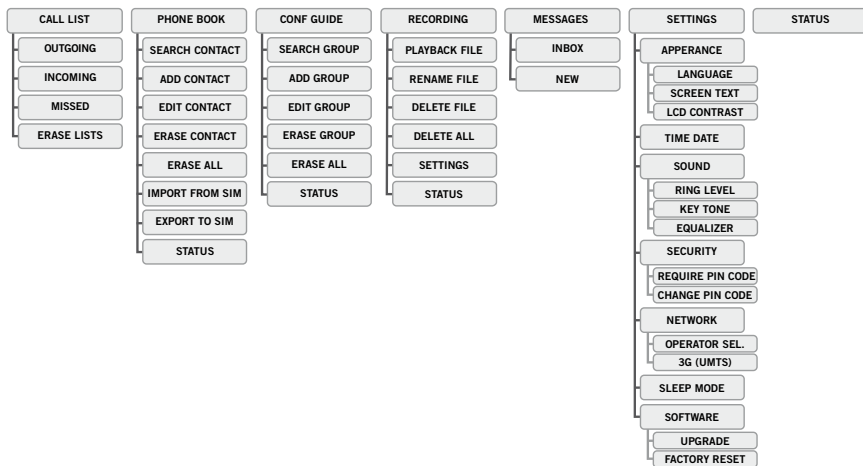

UNPACKING

- ⇒ Check that all parts are included in the package. If any parts are missing, please contact your retailer.
- The Konftel 300M conference phone
 - Battery
 - Charging cradle
 - 7.5 metre power cable for charging stand/Konftel 300M
 - AC adapter
 - 1.5 metre USB cable
 - Quick reference guides in different languages
- ① In addition to what is included in the package, a SIM card and subscription are required.

CONNECTING AND INSTALLING THE UNIT

⇒ Open the battery cover and insert the SIM card as illustrated.

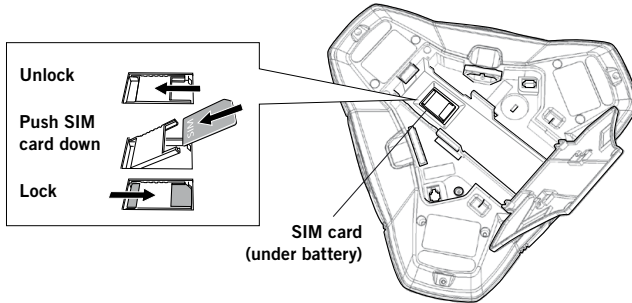

⇒ Insert the battery as shown in the picture.

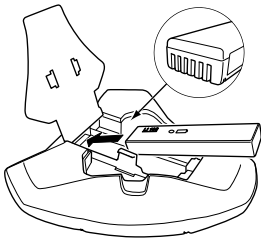

The Konftel 300M starts up and after a while an input window for the PIN code is shown in the display.

⇒ Enter the SIM card's PIN code and confirm with **OK**.

ⓘ You can opt to press **C** instead of entering your PIN code to start up Konftel 300M in USB mode.

⇒ Place the conference phone in the middle of the table.

ⓘ Place the conference phone at least 20 cm from the users.

USB mode

If the telephone is started up without a SIM card or if you press **C** during start-up when the telephone asks for the PIN for the SIM card, the telephone will start up in USB mode instead. This is indicated by the display showing the text USB instead of signal strength.

In USB mode all settings and options relating to mobile calls are removed. Instead a new option appears in the settings menu: **MENU > SETTINGS > ENABLE SIM**. This restarts the telephone so that the PIN code can be entered.

CONNECTION TO A PC

⇒ Connect the Konftel 300M to a computer using the USB cable provided.

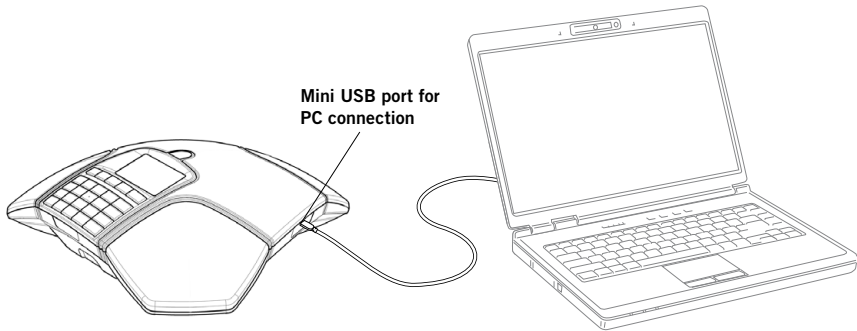

⇒ Check that **Konftel 300M USB Audio** is selected as the sound unit in the computer's settings.

Use as a conference unit

When connected to a PC, the Konftel 300M functions as a conference unit for VoIP calls, which means that speakers and microphones are activated, as is advanced sound management in OmniSound® HD. The microphone can be turned off using the **∅ (Mute)** button.

VoIP (Voice over IP) calls are transmitted as data packets over the network/Internet. For calls via PCs, you need VoIP software (e.g. Microsoft Lync or Skype®) or a service for web meetings whereby several users can communicate and share documents via their web browser or special client software.

📌 Some VoIP software has automatic adjustment of microphone and speaker levels as standard. In certain situations this can produce a pulsating sound or cause problems with full duplex. In such cases, switch off the automatic level regulation if possible, and set the software manually to a suitable microphone level, allowing Konftel 300M to manage sound processing.

BRIDGE CONNECTION

As default, the sound via the mobile network and USB is bridge-connected. It is possible to turn off the bridging if you do not want any sound from the computer to be heard during mobile calls.

⇒ Press the **LINE MODE** button.

⇒ Select bridging to be **ENABLED** or **DISABLED** and confirm by pressing **OK**.

RECHARGING BATTERIES

The Konftel 300M lets you know when the battery's remaining capacity is less than one hour of talk time. An audible signal is emitted and the LEDs flash three times. The battery recharging symbol on the display screen will also start flashing.

⇒ Recharge the Konftel 300M by placing it on the charging stand.

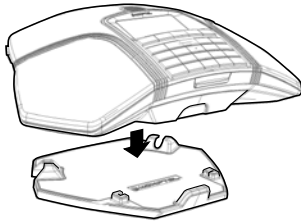

ⓘ The battery can also be recharged by plugging the power cable into the Konftel 300M.

Batteries

The battery has a button to display the battery's remaining capacity.

The Konftel 300M comes with a charged battery, but it may need recharging to full capacity depending on how long it has been in storage.

A fully-charged battery provides talk time of about 30 hours or 25 days of standby time. The Konftel 300M automatically switches to sleep mode after a few minutes of inactivity.



Warning!

- Do not attempt to open or modify the battery.
- Do not expose the battery to moisture or extreme heat.
- Extreme heat, short-circuiting or any attempt to modify the battery may cause it to ignite or explode.
- Only use the battery provided or a Konftel-recommended replacement battery.

Battery charger (optional)

The optional battery charger allows for external recharging of one or two batteries. Charge status is denoted by the LED for each charging channel on the charger. The LED is red during charging and green when the battery is fully charged. A red flashing LED indicates that the battery is damaged and must be replaced.

ANSWERING AND MAKING CALLS

ANSWERING CALLS

A ring tone is heard and the blue LEDs start flashing.

⇒ Press  to answer.

The LEDs show a steady blue light. The duration of the call is shown on the display screen.

MAKING CALLS

⇒ Dial the number.

⇒ Press .

The number is called and the LEDs show a steady blue light. The duration of the call is shown on the display screen.

Redialling

⇒ Press an arrow button or .

The last number that you dialled appears on the display screen.

⇒ Use the arrow buttons to look through previously dialled numbers.

⇒ Press .

The number you select is dialled.

You can also call via the telephone's call lists, where, as well as outgoing numbers, you can also find incoming calls and missed calls.

⇒ Select **MENU > CALL LIST**.

⇒ Select **OUTGOING**, **INCOMING** or **MISSED**, select a number from the list and press .

The selected number is called.

Calling from the phonebook

Please turn to page 17 for instructions on adding and updating contacts in the phonebook.

⇒ Press and hold down a number button for two seconds.

The phonebook appears on the display screen. The pre-programmed names appear in alphabetical order, starting with the number button's first letter.

⇒ Use the arrow buttons to look through the phonebook.

⇒ Press .

The contact you select is dialled.

MAKING MULTI-PARTY CALLS

Read about how to make multi-party calls using Konftel 300M under CONFERENCE GUIDE on page 13.

DURING A CALL

ADJUSTING THE SPEAKER VOLUME

⇒ Adjust the speaker volume using the buttons + and -.

Adjusting the speaker volume when multiple lines are connected

If you have selected multiple lines, you can adjust the volume level for each line. This is useful if the lines have different volume levels.

⇒ Press the + or - key to display the current volume setting.

The current main volume appears on the display screen. Above it are three smaller volume indicators which can be used to adjust the different connection lines.

⇒ Increase or decrease the speaker volume for all lines in the normal way using the + and - keys.

⇒ Use the arrow keys to mark one of the connected lines.

⇒ Adjust the speaker volume for the selected connection line using the keys + and -.

PLACING CALLS ON TEMPORARY HOLD

Mute

⇒ Press (Mute) to turn off the microphone.

The LEDs change from blue to red. The other party cannot hear what you are saying.

⇒ Press (Mute) to reconnect the call.

Hold

⇒ Press **HOLD** to put the call on hold.

The LEDs change from blue to flashing red. Both the microphone and the speaker are turned off and the call is on hold.

⇒ Press **HOLD** to reconnect the call.

ENDING CALLS

⇒ End the call by pressing .

CONFERENCE GUIDE

The conference guide allows you to create 20 conference groups with up to six people in each. You then call the group by simply pressing a few buttons.

- ① Please note! Some service providers and subscriptions have restrictions for multi-party calls, which means that certain functions will not work. Contact your service provider for more information.



MAKING MULTI-PARTY CALLS

If you make a lot of multi-party calls to a particular group, the simplest thing to do is create a conference call group in the conference guide. You can also add people manually during a call as follows:

- ⇒ Press  or **MENU > ADD PART.**

Calls in progress are put on hold.

- ⇒ Dial the second participant's number, press **OK** or  and wait for an answer.

- ⇒ Press the  (**Conference**) button to connect all parties or the  button to end the latest call and return to the earlier ones.

A list of ongoing calls is shown on the display. You can use the arrow buttons to scroll down the list if there are more than three calls.

ANSWERING INCOMING CALLS DURING A CALL

- ① Please note! The “call waiting” service may need to be enabled by your provider for this to work. The service can usually also be activated from the phone by pressing ***43#** .

Two tones will be heard and the blue LEDs start flashing.



- ⇒ Press  to answer.

Calls in progress are put on hold.

- ① Press  to reject the incoming call and continue the original call.

- ⇒ Press the  (Conference) button to connect all parties or the **XX** button to end the latest call and return to the earlier ones.

MANAGING MULTI-PARTY CALLS

You can put the call on hold (**HOLD**) or switch off the microphone ( **Mute**) even during a multi-party call. However, it is not possible to do this for individual parties. When all parties are connected in an active conference call, the entire call can be ended using the  button.

CREATING CONFERENCE GROUPS

- ① Please turn to page 4 for instructions on using the keypad to enter text.
- ⇒ Select **MENU > CONF GUIDE > ADD GROUP**.
- ⇒ Enter a group name and press **OK** to confirm.
- ⇒ Press **OK** to enter the first person.
- ⇒ Write the name of the first person and press **OK** to confirm.
- ⇒ Enter the number and press **OK** to confirm.
- ⇒ Press **OK** to add another person and repeat the above steps.
- ⇒ Conclude by pressing **C**.

MAKING CONFERENCE GROUP CALLS

- ⇒ Press the **☎ (Conference)** button.
- ⇒ Select the conference group you want to call.
- ① You can use the arrow buttons to press an alphanumeric button to jump to the first name that starts with that letter in the list.
- ⇒ Press **OK** if you want to see who is in the group before you make the call.
(Then press **OK** again or **▲** to call.)
Press **▲** directly if you want to make the call without first checking who is in the group.
The Konftel 300M dials the first person and asks you to confirm when the person answers.
- ⇒ Press **OK** when the first person has answered.
- ⇒ Continue in the same way for each person in the group.
Please note that calls in progress are put on hold when you make the next call.
- ① Please note that you can also call a conference group via **SEARCH GROUP** in the **CONF GUIDE** menu.

If you don't get an answer

- ⇒ Press **C** if one of the persons you are trying to call does not answer.
If the person does not answer, you can either end the conference guide or continue to the next person.
- ⇒ Press **OK** to continue and **C** to end the guide.
When the guide has ended, you will be connected with up to six people and ready to start your conference.

DISPLAYING CONFERENCE GROUP PARTICIPANTS

⇒ Select **MENU > CONF GUIDE > SEARCH GROUP**.

⇒ Mark the group you want and press **OK**.

The names of the conference group participants are displayed.

⇒ Press **C** to return to the CONFERENCE GUIDE menu or **MENU** to exit the menu. Press **OK** or  to dial the group.

EDITING CONFERENCE GROUPS

⇒ Select **MENU > CONF GUIDE > EDIT GROUP**.

Here, you can change the name of a conference group, add or delete a person from a group and change a person's name and phone number.

⇒ Mark your choice of option in the menu and press **OK** to confirm.

The names of the conference groups are displayed.

⇒ Mark the group you want to change and press **OK** to confirm.

⇒ Mark a person you want to change and press **OK** to confirm.

⇒ Make the change and press **OK** to confirm.

① Delete a number or a letter in a name by pressing **C**. If you want to cancel the change you are making and leave the name or number as they were, press **C** until the CONFERENCE GUIDE menu appears.

DELETING CONFERENCE GROUPS

⇒ Select **MENU > CONF GUIDE > ERASE GROUP**.

⇒ Mark the group you want to delete and press **OK**.

⇒ Confirm that you really want to delete the group by pressing **OK** or cancel the deletion of a group by pressing **C**.

DELETE ALL CONFERENCE GROUPS

⇒ Select **MENU > CONF GUIDE > ERASE ALL**.

⇒ Confirm that you really want to delete all groups by pressing **OK** or cancel the deletion of all groups by pressing **C**.

DISPLAYING CONFERENCE GUIDE STATUS

⇒ Select **MENU > CONF GUIDE > STATUS**.

The display screen indicates the number of conference groups already stored plus how many more groups can be added.

PHONEBOOK

The Konftel 300M has a phonebook that holds up to 200 entries. See page 11 for making calls via the phonebook.

- ① Please turn to page 4 for instructions on using the keypad to enter text.

SEARCHING FOR CONTACTS

⊕ The simplest way to search for a contact in the address book is to hold down a number button for two seconds (see page 11). You can also search for a contact via the PHONEBOOK menu.

⇒ Select **MENU > PHONE BOOK > SEARCH CONTACT**.

⇒ Mark the contact you want.

① You can use the arrow buttons to press an alphanumeric button to jump to the first name that starts with that letter in the list.

⇒ Press **OK** or  to dial the selected contact, **C** to return to the PHONEBOOK menu or **MENU** to exit the menu.

ADDING CONTACTS

⇒ Select **MENU > PHONE BOOK > ADD CONTACT**.

⇒ Enter the name of the contact and press **OK** to confirm.

⇒ Write the number and press **OK** to confirm.

⇒ Press **OK** to add another contact or **MENU** to exit the menu.

EDITING CONTACTS

⇒ Select **MENU > PHONE BOOK > EDIT CONTACT**.

⇒ Mark the contact you want to change. Press **OK** to confirm.

⇒ Make the change and press **OK** to confirm.

① Delete a number or a letter in a name by pressing **C**. If you want to cancel the change you are making and leave the name or number as they were, press **C** until the PHONEBOOK menu appears.

DELETING CONTACTS

- ⇒ Select **MENU > PHONE BOOK > ERASE CONTACT.**
- ⇒ Mark the contact you want to delete and press **OK.**
- ⇒ Confirm that you really want to delete the contact by pressing **OK** or cancel the deletion of a contact by pressing **C.**

DELETING ALL CONTACTS

- ⇒ Select **MENU > PHONE BOOK > ERASE ALL.**
- ⇒ Confirm that you really want to delete all contacts by pressing **OK** or cancel the deletion of a contact by pressing **C.**

COPYING CONTACTS

Contacts in the phone book are stored in the telephone's memory. You can copy contacts to and from the SIM card to move them between different telephones.

Import from SIM card

- ⇒ Select **MENU > PHONE BOOK > IMPORT FROM SIM.**
All contacts on the SIM card are copied to the phone book. Existing contacts in the phone book are not erased, but any duplications (same name and number) are not copied.

Export to SIM card

- ⇒ Select **MENU > PHONE BOOK > EXPORT TO SIM.**
All contacts in the phone book are copied to the SIM card. Existing contacts on the SIM card are not erased, but any duplications (same name and number) are not copied.

DISPLAYING PHONEBOOK STATUS

- ⇒ Select **MENU > PHONE BOOK > STATUS.**
The display screen indicates the number of contacts already stored plus how many more contacts can be added.

RECORDING

It is possible to record a phone conference on an SD (Secure Digital) memory card so you can listen to it later on. It is possible to record a call in progress and use the Konftel 300M as a dictaphone.

A flashing symbol appears on the display screen during recording. A beep is heard every 20 seconds so that other parties in the call know it is being recorded. The beep can be turned off (see page 21).

The recorded call is saved on the memory card. The document is named after the time at which the recording began (e.g. 14-35-01.wav) and is saved in a folder with the current date. This name can be changed after the recording has ended (see page 21).

STARTING A RECORDING

Remember to notify all parties in the call before you start recording.

⇒ Press the **REC/C** button for two seconds and press **OK** to confirm.

The recording symbol flashes on the display screen.

MUTE FUNCTION

⇒ Press the **∅ (Mute)** button during a call to turn the microphone off.

The LEDs change from blue to red.

The other party cannot hear what you are saying and only the called party is recorded.

HOLD

⇒ Press **HOLD** during the call to put the call on hold.

The LEDs change from blue to flashing red.

Both the microphone and the speaker are turned off and the call is on hold. None of the parties will now be recorded.

ENDING A RECORDING

⇒ Press the **REC/C** button for two seconds and press **OK** to confirm.

The recording symbol is no longer displayed on the screen.

① If you are recording a call and the call is ended, you will be asked if you want to stop recording.

LISTENING TO A RECORDING

You can listen to a recorded phone conference on your Konftel 300M or a computer using an SD memory card reader. Recordings are saved in wav format and can be played back on your choice of media player.

Listening to recordings on the Konftel 300M:

⇒ Select **MENU > RECORDING > PLAYBACK FILE.**

⇒ Mark the folder you want (date) and press **OK** to confirm.

A list of all recordings for the specified date is displayed. Names, date, time and length are displayed for each recording.

⇒ Mark the recording you want and start the playback by pressing **OK.**

Adjusting the speaker volume

⇒ Increase the volume using the **▲ +** button and lower it using **▼ -**.

Pause playback

⇒ Pause the playback by pressing **OK.**

⇒ Restart playback by pressing **OK** again.

Move forward in the recording during playback

⇒ Move forward in the recording by pressing arrow down or backward by pressing arrow up.

① The recording advances about 10 seconds every time you press the button.

You can also jump further forward in the recording:

Key 3 – forward 1 minute

Key 6 – forward 10 minutes

Key 1 – backward 1 minute

Key 4 – backward 10 minutes

Stop playback

⇒ Stop the playback by pressing **C.**

MANAGING RECORDINGS

Editing the name of a recording

① The recording is named by default with the time at which the recording started.

- ⇒ Select **MENU > RECORDING > EDIT FILE**.
- ⇒ Mark the folder you want and press **OK** to confirm.
- ⇒ Mark the recording to be edited and press **OK**.
- ⇒ Make the change and press **OK** to confirm.

① Delete a number or a letter in a name by pressing **C**.

If you want to cancel the change you are making and leave the name or number as they were, press **C** several times until the RECORDING menu appears.

Deleting a recording

- ⇒ Select **MENU > RECORDING > DELETE FILE**.
- ⇒ Mark the folder you want and press **OK**.
- ⇒ Mark the recording to be deleted and press **OK**.
- ⇒ Confirm that you really want to delete the recording by pressing **OK** again, or cancel the deletion of a recording by pressing **C**.

Deleting all recordings

- ⇒ Select **MENU > RECORDING > DELETE ALL**.
- ⇒ Confirm that you really want to delete all recordings by pressing **OK** again, or cancel the deletion of a recording by pressing **C**.

ADJUSTING THE RECORDING INDICATOR

A short beep is heard every 20 seconds so that all the parties in the call know it is being recorded. This feature can be turned off.

- ⇒ Select **MENU > RECORDING > SETTINGS**.
- ⇒ Select your choice and press **OK** to confirm.

DISPLAYING RECORDING FEATURE STATUS

- ⇒ Select **MENU > RECORDING > STATUS**.

The display screen indicates the number of recordings, the total length of recorded calls and how many hours of recording time are left before the memory card is full.

MESSAGES

You can read messages (SMS) on Konftel 300M. All messages are stored on the SIM card.

READ AND ERASE A MESSAGE

⇒ Select **MENU > MESSAGES > INBOX**.

The messages in your inbox are displayed in chronological order, with the most recent at the top.

⇒ Highlight the required message and press **OK** to display the content.

⇒ Press **C** when you have finished reading.

You will be asked if you want to erase the message.

⇒ Press **OK** to erase the message or **C** to return to the list of messages and leave the message in the inbox.

SEND A MESSAGE

⇒ Select **MENU > MESSAGES > NEW**.

⇒ Enter the telephone number to which the message is to be sent and confirm by pressing **OK**.

⇒ Write your message and confirm by pressing **OK**.

You will be asked if you want to send the message.

⇒ Confirm by pressing **OK** or cancel by pressing **C**.

① Please note that sent messages are not saved.

SETTINGS

APPERANCE

Selecting languages

- ⇒ Select **MENU > SETTINGS > LANGUAGE**.
- ⇒ Select the language you want and press **OK** to confirm.

Changing text on the display screen

The text on the display screen can be changed when the Konftel 300M is on hook.

- ⇒ Select **MENU > SETTINGS > SCREEN TEXT**.
- ⇒ Delete existing text using **C** and enter your new text. Press **OK** to confirm.

Adjusting LCD contrast

- ⇒ Select **MENU > SETTINGS > LCD CONTRAST**.
- ⇒ Select your choice and press **OK** to confirm.

ADJUSTING DATE AND TIME

Changing the date

- ⇒ Select **MENU > SETTINGS > TIME DATE > DATE**.
- ⇒ Change the flashing figures for the year using the arrow buttons or by entering the figures on the keypad. Press **OK** to confirm and to continue to the month, and then proceed in the same way for the day.

Changing the time

- ⇒ Select **MENU > SETTINGS > TIME DATE > TIME**.
- ⇒ Change the flashing figures for the hour using the arrow buttons or by entering the figures on the keypad. Press **OK** to confirm and to continue to minutes.

Changing the time format

- ⇒ Select **MENU > SETTINGS > TIME DATE > TIME FORMAT**.
- ⇒ Select either a 12-hour or a 24-hour format using the arrow buttons and press **OK** to confirm your choice.

SOUND

Adjusting ring level volume

⇒ Select **MENU > SETTINGS > SOUND > RING LEVEL.**

⇒ Select your choice and press **OK** to confirm.

① There are six volume levels plus a silent mode. You will hear the ring tone for each level you select. If you select silent mode, an LED on the phone flashes when an incoming call is received.

Deactivating keypad tones

You can select whether or not you want a tone to be heard when you press a button. Note that this setting does not affect the tone you hear when you dial a number in call mode.

⇒ Select **MENU > SETTINGS > SOUND > KEY TONE.**

⇒ Select your choice and press **OK** to confirm.

Adjusting sound (equalizer)

The sound reproduction can be adjusted to the required pitch (SOFT, NEUTRAL and BRIGHT).

⇒ Select **MENU > SETTINGS > SOUND > EQUALIZER.**

⇒ Select your choice and press **OK** to confirm.

SECURITY

The PIN code is used to enable the SIM card when the telephone is started up. The code is supplied with the SIM card. The original code can be changed to any code of your choice comprising 4 digits, or it can be disabled so that the telephone can be started up without a code.

⇒ If the wrong PIN code is entered three times in a row, it becomes invalid. The SIM card must then be unlocked using the PUK code which was also supplied with the SIM card.

State whether or not a PIN code will be required

⇒ Select **MENU > SETTINGS > SECURITY > REQUIRE PIN CODE.**

⇒ Make your choice and confirm by pressing **OK.**

Change PIN code

⇒ Select **MENU > SETTINGS > SECURITY > CHANGE PIN CODE.**

SETTINGS

- ⇒ Enter the current PIN code and confirm by pressing **OK**.
- ⇒ Enter the new PIN code and confirm by pressing **OK**.
- ⇒ Re-enter the new PIN code and confirm by pressing **OK**.

The PIN code is now changed. Make a note of the new PIN code and keep it in a safe place.

ENABLE SIM CARD

If the telephone is started up without the correct PIN code being entered, this menu appears, for enabling the SIM card afterwards.

- ⇒ Select **MENU > SETTINGS > SECURITY > ENABLE SIM**.
- ⇒ Press **OK** to restart the telephone so that you can enter the PIN code and enable the SIM card.

NETWORK

Service provider selection

It is possible to lock the telephone so only one particular provider can be used. This can be useful if, for example, the telephone is used outside the usual provider's coverage area or near a national border where a foreign provider has a strong reception.

- ⇒ Select **MENU > SETTINGS > NETWORK > OPERATOR SEL..**
Konftel 300M performs a search of the available mobile networks and displays them in a list.
- ⇒ Select the network you want the telephone to be locked to.
- ⓘ Please note that the SIM card in the telephone will probably not function with all networks, and that Konftel 300M may be locked to a particular provider.

Enable 3G

3G is enabled by default. If the telephone is located in a place with very poor 3G coverage, this network may be switched off in order to force the telephone to use the GSM network. This may reduce disruptions to calls and may extend the life of the battery.

- ⇒ Select **MENU > SETTINGS > NETWORK > 3G (UMTS)**.
- ⇒ Press **OK** to switch between 3G enabled (filled box) and 3G disabled (empty box).

SETTINGS

SLEEP MODE

It is possible to deactivate the sleep mode.

⇒ Välj **MENU > SETTINGS > SLEEP MODE**.

⇒ Select sleep mode to be **ENABLED** or **DISABLED** and confirm by pressing **OK**.

SOFTWARE

Upgrading

This menu option restarts the Konftel 300M in upgrade mode. See page 27.

Resetting

There is a menu option under SETTINGS that resets all settings to default. Please note that this also deletes all contacts in the phonebook and all groups saved in the conference guide.

⇒ Select **MENU > SETTINGS > SOFTWARE > FACTORY RESET**.

⇒ Confirm that you really want to reset the settings to default by pressing **OK** again, or cancel the resetting procedure by pressing **C**.













CHECKING STATUS

If you need to check the software version or serial number.

⇒ Select **MENU > STATUS**.

SET CALL FORWARDING

Call forwarding is a service set up by the provider and is linked to the SIM card, not the phone. You can check the current setting and change it from Konftel 300M by entering a code according to the table below. Contact your service provider for more information.

Forward service	Activate	Cancel	Check status
All calls	*21*[phone number]# 	#21# 	*#21# 
If busy	*67*[phone number]# 	#67# 	*#67# 
If not answered	*61*[phone number]# 	#61# 	*#61# 
If out of reach	*62*[phone number]# 	#62# 	*#62# 

UPGRADING SOFTWARE

The Konftel 300M is continually being developed with smart features and the software can be upgraded to ensure the unit is always running the latest software version.

UPGRADING FROM A PC

Installing Konftel Upgrade utility

- ⇒ Visit www.konftel.com/upgrades and select Konftel 300M.
- ⇒ Click to download Konftel Upgrade utility.
- ⇒ Install the software on your computer.
Follow the instructions given by the installation program.

Updating software

- ⇒ Start the Konftel Upgrade utility software on your computer from the Start menu.
Follow the instructions that the software guide gives you.
- ① We recommend that you let Konftel Upgrade utility automatically download and install the latest version from Konftel's website. You can also install a Konftel firmware file that has already been downloaded to the PC's hard drive.

TECHNICAL SPECIFICATIONS

Size	Diameter 240 mm, height 77 mm
Weight	1 kg
Colour	Liquorice black
Display screen	Illuminated graphics (LCD), 128x64
Keypad	Alphanumeric 0–9, *, off hook, on hook, mute, hold, volume up, volume down, 5 buttons for menu navigation, line mode, conference guide
Anti-theft protection	Kensington security slot
Memory	Support for SD memory cards up to 2 GB
SIM card	Mini-SIM
Upgrades	The Konftel Upgrade utility upgrades Konftel 300M software via the USB connection

Connectivity

Cellular network	U.S. version (840101070), 2G: GSM 850/900/1800/1900 3G: UMTS 850/1900 European version (910101070), 2G: GSM 850/900/1800 3G: UMTS 900/2100
Computer	USB 2.0 Mini B
Power supply	Battery: Emerging Power Li 18S, 7.2 V 5200 mAh Lithium ion Konftel charging cradle
Expansion microphones	2 modular 4/4

Konftel charging station

AC adapter	Model S024EM1400150 100–240 V AC / 14 V DC, 1.5 A, charging 8,4 V 0,75 A
------------	---

Audio

Technology	OmniSound® HD
Microphone	Omni-directional
Reception area	Up to 30 metres ² , >10 people
Speaker, frequency band	200–3300 Hz, mobile 2G/3G 200–7000 Hz, USB VoIP
Volume	90 dB SPL 0.5 m
Equalizer	Three pitches: soft, neutral, bright

TECHNICAL SPECIFICATIONS

Environment

Temperature 5°–40°C

Relative humidity 20–80% condensation free

Recommended acoustic conditions

Reverberation period: 0.5 S Rt 60

Background noise: 45 dBA

SERVICE AND GUARANTEE

If anything is wrong with your Konftel unit, please contact the place of purchase.

Guarantee

We give a two-year guarantee on our conference telephones.

Service

Service is offered after the expiration of the guarantee. Please contact your retailer and ask for a cost estimate.

Konftel support

If you have any questions about the guarantee and service, please contact your Konftel support centre

Europe: +46(0)90-706 489 (Monday–Friday 8.00–17.00 GMT+1)

E-mail: rma@konftel.com

USA and Canada:

+1 866-606-4728 (Monday–Friday 08.00–17.00 GMT-8)

E-mail: konftel.usa@konftel.com

Konftel is a leading company and the world's fastest growing brand, within audio conferencing equipment. Since 1988, our mission has been to help people around the world to conduct meetings despite distances. Based on our success, we know that audio conferencing is a great way to save time, money and at the same time contribute to a better environment. High audio quality is essential for efficient meetings, this is why our patented audio technology OmniSound®, is built into all Konftel Conference phones. The products are sold globally under the Konftel brand and our head-quarter is based in Sweden. Read more about the company and products on **www.konftel.com**



Konftel AB, Box 268, SE-901 06 Umeå, Sweden

Phone: +46 90 706 489 Fax: +46 90 131 435 E-mail: info@konftel.com

www.konftel.com